

# INSTALLATION INSTRUCTIONS

## DuoCare™

Recessed Exam Fixture

Model: DCE Series

**ALKCO®**

11500 Melrose Avenue  
Franklin Park, Illinois 60131  
Phone: 847-451-0700  
Fax: 847-451-7512  
www.alkco.com

### CAUTION! - READ THIS FIRST --- IMPORTANT SAFETY INSTRUCTIONS

- \* Carefully read the instructions pertaining to your fixture. IF YOU HAVE ANY QUESTIONS REGARDING THE PROPER INSTALLATION OR LOCAL CODES, CONSULT A QUALIFIED ELECTRICIAN.
- \* To avoid shock hazard, do not work with live electrical wires.
- \* Install the fixture in only dry, indoor applications.
- \* Do not install outdoors or in applications other than the intended use.
- \* Install and wire the fixture in locations in accordance with all national, state and local codes.
- \* For 277V installations, disconnect the safety disconnect plug(s) (located in the wireway compartment) to fully disconnect power to the fixture before servicing. (See Figure 1)

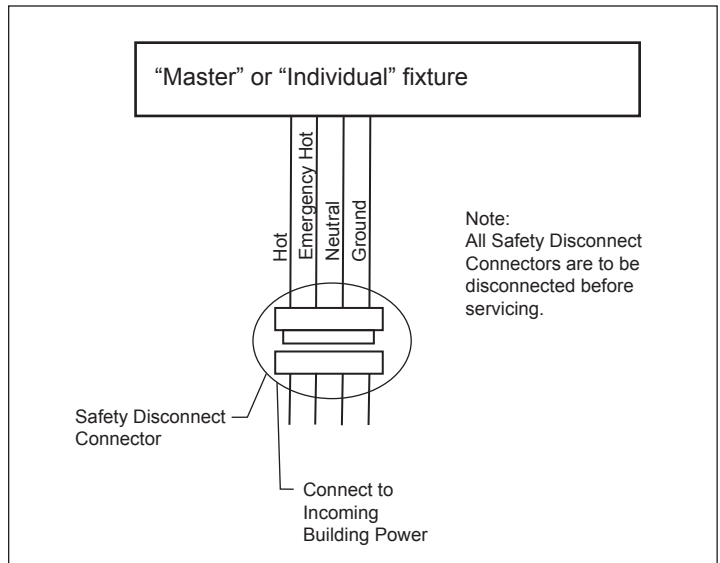

**WARNING:** THIS PRODUCT MUST BE INSTALLED IN ACCORDANCE WITH THE APPLICABLE INSTALLATION CODE BY A PERSON FAMILIAR WITH THE CONSTRUCTION AND OPERATION OF THE PRODUCT AND THE HAZARDS INVOLVED.

**WARNING:** RISK OF FIRE, MINIMUM OF 90°C SUPPLY CONDUCTORS. CONSULT A QUALIFIED ELECTRICIAN TO ENSURE CORRECT BRANCH CIRCUIT CONDUCTOR.

**WARNING:** TO AVOID SHOCK HAZARD DISCONNECT THE POWER AT THE PANEL BOARD (CIRCUIT BREAKER BOX).

## OVERVIEW

To insure proper installation, read through entire Installation Instructions prior to beginning the installation.

DuoCare™ Exam fixtures are available in 3 different housing models:

### 1. "Master"

The "Master" model works in conjunction with a "Satellite" model. The "Master" fixture has the ballasts and optional equipment (i.e. emergency ballast) to operate both the "Master" and "Satellite" fixture. The incoming power is brought to the "Master" fixture and has an interconnect whip (of a specified length) to connect the "Satellite" fixture. Quick connector plugs on the interconnect whip simplify the wiring of the "Satellite" fixture to the "Master" fixture. (See Figure 2)

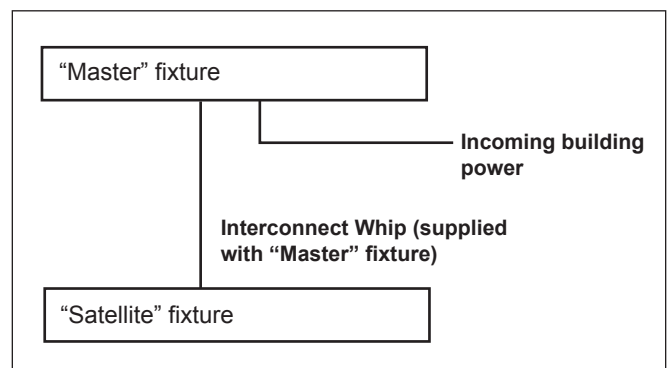

## 2. “Satellite”

The “Satellite” model does not house any of the electrical control gear. It must have a companion “Master” fixture to connect to. It does not require a building power connection.

**Note:** For “Master/Satellite” applications, it is recommended that the “Master” fixture is installed first.

## 3. “Individual (stand alone)”

The “Individual” model is intended for applications where only one fixture is needed or for applications where a pair of fixtures is needed (i.e. patient room bed application) but a “Master/Satellite” system is not desired. Each fixture has its own ballasts and optional equipment.

Throughout the remainder of this document, these different models will be referred to as “Master”, “Satellite”, or “Individual” for simplicity. You can easily identify what model you have by looking for the label on the wiring compartment cover located on the side of the housing.

The typical installation for the DuoCare™ Exam fixture is a pair of fixtures to illuminate a patient bed surface. Fixtures are positioned to either side of the bed running parallel to the length of the bed. In addition, the DuoCare™ fixture has an asymmetrical distribution so the fixtures need to be properly oriented to perform properly. Figure 3 illustrates how the asymmetric distribution. The fixtures are labeled to help guide you on the proper orientation.

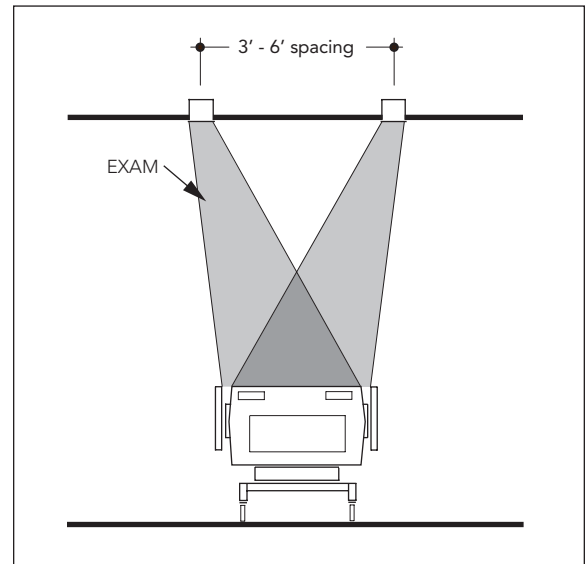

Figure 3

## A. CEILING INSTALLATION

DuoCare™ fixtures are available in for either grid or flange installations. Identify which model you have and continue to the appropriate section below.

### 1. Grid Ceiling Applications

- Inspect the ceiling grid to make sure it is supported from the building structure as recommended by the ceiling grid manufacturer's instructions. This must be approved before bearing the weight of the lighting fixture.
- DuoCare™ is designed to fit into standard 1" or 1½" high grid ceilings. Lift the fixture through the ceiling opening at an angle and then lower it so it is resting on the ceiling grid. An additional ceiling grid runner will have to be added to support one or both of the long edges of the fixture depending on where it falls within the ceiling opening. This fixture has an asymmetric light distribution. Be sure you have oriented the fixture per the label on the lens protective wrap.
- For additional support, the bend-up hanger tab can be used to wire tie the fixture directly to the ceiling structure. (See Figure 4) Earthquake clips are also available as an option and separate installation instructions are provided for attaching them to the DuoCare™ fixture and properly using them in the installation.
- If you are installing a “Master” or an “Individual” fixture, continue to “Section B – Making Building Power Connections” to complete the installation. If you are installing a “Satellite” fixture, continue to “Section C – Connecting the Interconnect Whip” to complete the installation.

### 2. Flange Applications

- The flange version of DuoCare™ is designed to install into drywall (i.e. gypsum board, sheetrock) ceilings.
- Carefully, determine the desired placement of the fixtures and cut an opening of 6-1/4" x 48-5/8". The installation requires a clean and accurate opening to be cut into the ceiling surface. The opening needs to be cut square and accurate to a 1/16" of the provided dimension. The cut opening should be into whole pieces of ceiling material to minimize seams and joints intersecting the opening. This limits the stress on taped joints and ensures a better fit of the fixture flange against the ceiling surface.

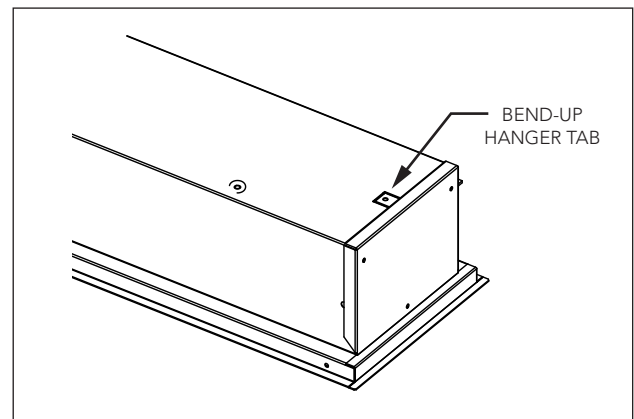

Figure 4

- c.) The ceiling surface should be free of bowing and the area around the ceiling opening should be finished to a smooth and flat surface free of imperfections. The elevation on the ceiling surface should not deviate more than 1/32" over 2' of horizontal surface.
- d.) Rigid framing (i.e. C-channel) around the cut opening should be installed with the inside edge of the frame positioned flush with the cut opening. The ceiling material should be secured to the bottom surface of the framing. The combined thickness of the ceiling material and rigid framing should not exceed 2 3/4". (See Figure 5)
- e.) If you are installing an "Individual" fixture, continue to "Section B – Making Building Power Connections" before returning to Step 2f below to complete the installation.

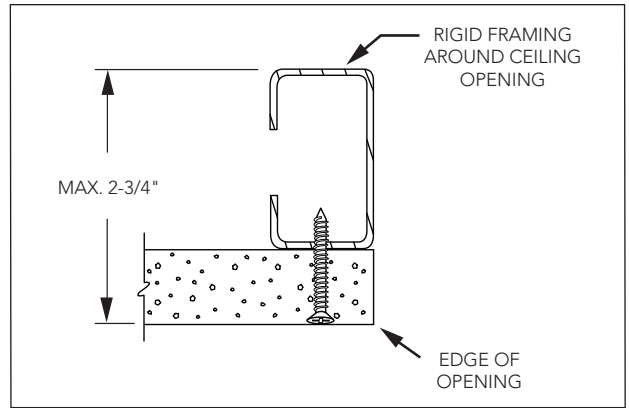

Figure 5

If you are installing a "Master" fixture, continue to both "Section B – Making Building Power Connections" and "Section C – Connecting the Interconnect Whip" before returning to Step 2f below to complete the installation.

If you are installing a "Satellite" fixture, continue to "Section C – Connecting the Interconnect Whip" before returning to Step 2f below to complete the installation.

- f.) It is assumed that the necessary building power and/or interconnect whip have been wired to the fixture before beginning this step. If not, return to the Step 2e above and follow those directions.

Carefully, pull back the protective wrap on the fixture lensed door so that the three screws can be removed and the door opened. Keep the protective wrap on the lens to keep it from being damaged. Loosen all of the door screws, alternating between them until the door can be opened.

- g.) Check to make sure that the tape is removed from the (4) sway bar brackets located at the corners of the fixture housing. Once the tape is removed, make sure that the sway bar wings are pushed against the housing wall.
- h.) The fixture has an asymmetric light distribution pattern and must be installed in the proper orientation to function correctly. There is a green label on the protective lens wrap that indicates the proper orientation of the fixture in the ceiling.
- i.) Carefully, lift the housing through the ceiling opening while pushing any of the flexible conduit or interconnect cable through the opening as well. The flange should be resting against the underside of the ceiling surface.

**Note:** If installing the "Master" fixture, be sure that the interconnect whip will be accessible through the opening for the "Satellite" fixture before finalizing the installation of the "Master" fixture.

- j.) Hold the fixture in place against the ceiling. Allow the lensed door to hang open. Locate the (4) sway bracket adjustment screws located at the four corners of the housing. These are accessible from the inside of the housing. Use a Phillips screwdriver to turn the screws clockwise. (See Figure 6) This swings the bracket wing out away from the fixture and allows it to rest on the top side of the ceiling opening framing. When all (4) bracket wings have been swung away from the fixture, the fixture can support itself on the framing.
- k.) Continue turning the adjustment screws, alternating between the (4) corners, until the fixture and its flange pull up tight against the ceiling surface.
- l.) Follow the instructions for lamping the fixture (Section E – Installing Lamps), before closing the fixture door. When closing the door, hold the door closed and start threading the screws by hand-tightening to avoid cross-threading. Using a screwdriver (not a power driver), tighten the door screws until the door is held snug against the housing.

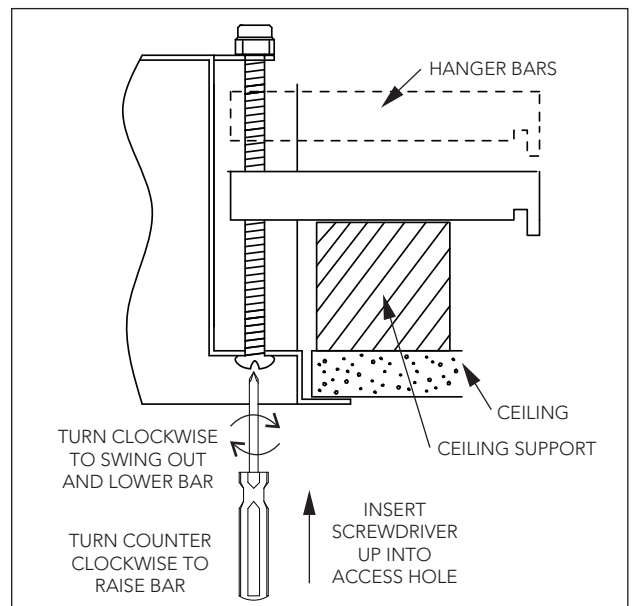

Figure 6

## B. MAKING BUILDING POWER CONNECTIONS

 **WARNING:** CHECK TO MAKE SURE THE POWER IS TURNED OFF AT THE CIRCUIT BREAKER BOARD BEFORE BEGINNING TO MAKE ELECTRICAL CONNECTIONS.

1. Locate the wiring compartment cover on the side of the fixture and remove it from the fixture. The wiring compartment cover has (2) 7/8" diameter knockouts. (See Figure 4) One of these knockouts will be used for connecting the flexible metal conduit (FMC) for the building power. The other is provided for the interconnect whip with "Master/Satellite" configurations. Remove a knockout from the cover.
2. Secure the FMC with the incoming power to the knockout on the wiring compartment cover with the appropriate conduit connector. Locate the leads for the safety disconnect connector. If an emergency ballast option has been ordered, an additional lead will be marked "Emergency". Make all necessary electrical connections with Incoming Hot connected to the appropriate black lead, Incoming Neutral connected to the appropriate white leads, and Incoming Ground connected to the appropriate green leads. (See Figure 1)

**Note:** *There is a safety disconnect plug(s) installed between the ballast and the incoming power. This plug(s) must remain accessible from inside the fixture housing. Refer to Figure 1 for further details.*

**Note:** *If the fixture is a "Master" fixture, go to "Section C – Connecting the Interconnect Whip" before continuing with the steps below.*

**Note:** *If the fixture has an emergency ballast, continue to "Section E – Emergency Ballast Connection" and complete those steps before continuing with the steps below.*

3. Carefully position all of the wires underneath the cover, making sure not to pinch any wires, and reinstall the cover to the housing.

## C. CONNECTING THE INTERCONNECT WHIP

1. An interconnect whip is provided to simplify the connection of the "Satellite" fixture to the "Master" fixture. Locate the interconnect whip. (It is packaged in a separate box.)
2. The interconnect whip has a pair of quick connectors added at both ends of the whip. If working with the "Master" fixture, identify the end of the interconnect whip where the connector is labeled "M1". The end of the interconnect whip with the connector labeled "S1" is intended for connection to the "Satellite" fixture.
3. Working with the appropriate end of the interconnect whip, push the connector through one of the knockouts on the wiring compartment cover. Secure the whip to the knockout.
4. Locate the connector, at the fixture, that is labeled to match the connector on the interconnect whip. Push the matching connectors together making sure they fit together tightly.
5. If installing a flanged fixture, return to Section A, Step 2f.

## D. EMERGENCY BALLAST CONNECTION

 **WARNING:** TO PREVENT HIGH VOLTAGE FROM BEING PRESENT ON OUTPUT LEADS PRIOR TO INSTALLATION, INVERTER BATTERY CONNECTOR MUST BE OPEN. DO NOT JOIN INVERTER BATTERY CONNECTOR UNTIL INSTALLATION IS COMPLETE AND AC POWER IS SUPPLIED TO THE EMERGENCY BALLAST. DISCONNECT FOR MAINTENANCE.

 **WARNING:** RISK OF FIRE, MINIMUM OF 90°C SUPPLY CONDUCTORS REQUIRED. CONSULT A QUALIFIED ELECTRICIAN TO ENSURE CORRECT BRANCH CIRCUIT CONDUCTOR.

 **WARNING:** TO AVOID SHOCK HAZARD DISCONNECT THE POWER AT THE PANEL BOARD (CIRCUIT BREAKER BOX).

**Note:** *Make sure that the necessary branch circuit wiring is available. An unswitched source of power is required. The emergency ballast must be fed from the same branch circuit as the AC ballast.*

1. Locate the safety disconnect connector in the wiring compartment and identify the lead labeled "Emergency". Connect the unswitched building power hot to the "Emergency" lead. (The emergency ballast must be fed from the same branch circuit as the AC ballast.) (See Figure 1)
2. The emergency ballast has an inverter battery connector which is disconnected for shipment. It must be reconnected only after installation of fixture and AC power is supplied. The battery connector is found inside the housing and is accessible when the reflector assembly is removed.
3. Locate the battery connector leads (the red and white wires with mating connectors) and snap them together. Position the mated connector to the inside of the fixture for servicing convenience.
4. If installing a flanged fixture, return to Section A, Step 2f.

## E. INSTALLING LAMPS

1. Loosen the screws that secure the lensed door to the housing. Alternate between the (3) screws until the door can be opened. Allow the door to swing open and hang perpendicular to the fixture aperture.
2. Check the lamping label located on the reflector near one of the sockets to make sure of the proper lamp to be used. Install the into the locked position.
3. When closing the door, hold the door closed and start threading the screws by hand-tightening to avoid cross-threading. Using a screwdriver (not a power driver), tighten the door screws until the door is held snug against the housing.

## F. BALLAST SERVICING

If there is a need to replace a ballast, the reflector assembly must be removed from the fixture to access the ballasts. Follow the steps below.

1. Loosen the screws that secure the lensed door to the housing. Alternate between the (3) screws until the door can be opened. Allow the door to swing open and hang perpendicular to the fixture aperture.
2. Locate the two screws at the lower edge of the reflector endplates. Remove both screws.
3. Gently pull the reflector assembly out of the fixture using the finger tabs located on the bottom edge of the endplates. Be sure to note the orientation of the reflector prior to removal.
4. Once the reflector assembly is free from the fixture, disconnect the plugs at each end of the reflector. The reflector assembly can be set aside. The ballasts are now accessible for servicing.
5. Repeat the steps in reverse to reinstall the reflector assembly making sure that it is reinstalled in the same orientation that it was before removal.

## G. CLEANING

1. Fixtures can be wiped down with a soft cloth lightly dampened with warm water and soapy water. Do not use ammonia based or abrasive cleaners.

## CUSTOMER SUPPORT

If you require additional information regarding this light fixture we invite you to call us at ALKCO. Our business hours are: Monday - Friday (except holidays), 8:00am to 4:30pm Central time. Phone: 847-451-0700, Fax: 847-451-7512

## WARRANTY

All luminaire components, except lamps and transformers, are warranted against defects during the life of the original installation (reference Alkco's buying guide for details).

## REPLACEMENT PARTS

Contact Alkco Lighting directly for information on replacement parts. When calling, be prepared to provide the model number and date of manufacture of the fixture. This information is indicated on labels located on the product.

.075.0370 08/09 DCE Series

 Some luminaires use fluorescent or high intensity discharge (HID) lamps that contain small amounts of mercury. Such lamps are labeled "Contains Mercury" and/or with the symbol "Hg." Lamps that contain mercury must be disposed of in accordance with local requirements. Information regarding lamp recycling and disposal can be found at [www.lamprecycle.org](http://www.lamprecycle.org)